

400 W. Artesia Blvd.
Compton, CA 90220
Fax: (310) 747-3912
Ph: 1-800-776-0767
E-Mail: info@procompusa.com
Website: www.procompusa.com

Latest Revision
Date:
7.22.2021



PRO COMP SUSPENSION

IMPORTANT!: *This kit cannot be used in conjunction with Factory wheels.*

51801/51801MX/51801BF
K1084B/ K1084BP/ K1084T/ K1084M
2wd/4wd 1999-2010 Silverado 6 Inch Lift Kit

This document contains very important information that includes warranty information and instructions for resolving problems you may encounter. Please keep it in the vehicle as a permanent record.

Box 1 of 4-PN 51801/51801MX/51801MXR/51801BF/51801BFR-1

Part

				Part #
91-5714	FRONT CROSSMEMBER	1	8,9	11,12
90-6727	HARDWARE PACK: Front Crossmember	1	-	-
70-0625501800	5/8" X 5" GR. 8 HEX BOLT	2	8	11
72-062100816	5/8" USS GR. 8 STOVER NUT	2	8	11
73-06200042	5/8" HARDENED FLAT WASHER	4	8	11
91-8020	CROSSMEMBER SUPPORT TUBE	2	10	12
90-5736	SQUARE BOLT PLATE: Front Crossmember	2	8	11
91-5708	DIFFERENTIAL MOUNT: Drvr	1	4	9
91-5711	DIFFERENTIAL MOUNT: Pass	1	6	10
90-6718	HARDWARE PACK: Drvr Differential Mount	1	-	-
71-100601501000	10mm-1.5 X 60mm HEX BOLT GR. 10.9	5	4	9
73-01010940	10mm HARDENED FLAT WASHER	5	4	9
90-6719	HARDWARE PACK: Differential Mounts	1	-	-
70-0504501800	1/2" X 4 1/2" HEX BOLT GR. 8	1	9	12
72-050100816	1/2" STOVER NUT GR. C	1	9	12
73-05000034	1/2" HARDENED FLAT WASHER	2	9	12
70-0564501800	9/16" X 1 1/2" HEX BOLT GR. 8	2	7	10
72-056100816	9/16" STOVER NUT GR. C	2	7	10
73-05600034	9/16" HARDENED FLAT WASHER	4	7	10
90-6657	HARDWARE PACK: Drvr Differential Mount	1	-	-
15-11326	BUSHING	2	4	9
90-2109	SLEEVE	1	4	9
90-6189	HARDWARE PACK: Differential	1	-	-
90-2216	DIFFERENTIAL VENT EXTENSION	1	-	-
90-2217	HOSE MENDER: 5/16"	1	-	-
91-8018	SWAY BAR END LINK	2	13	14
90-5730	SWAY BAR LOWER MOUNT	2	13	14
90-5738	SWAY BAR UPPER MOUNT	2	13	14
90-5739	SWAY BAR MOUNT PLATE	2	13	14
90-6720	HARDWARE PACK: Sway Bar	1	-	-
70-0561501800	9/16" X 1 1/2" HEX BOLT GR. 8	2	13	14
73-05600034	9/16" HARDENED FLAT WASHER	4	13	14
72-056100816	9/16" STOVER NUT GR. C	2	13	14
70-0371501800	3/8" X 2 1/2" HEX BOLT GR. 8	4	13	14
72-037100816	3/8" STOVER NUT GR. C	4	13	14
73-03700034	3/8" HARDENED FLAT WASHER	8	13	14
70-0621501800	5/8" X 2" HEX BOLT GR. 8	2	13	14
73-06200034	5/8" HARDENED FLAT WASHER	2	13	14
72-062100816	5/8" STOVER NUT GR. C	2	13	14
90-6721	HARDWARE PACK: Sway Bar Bushings	1	-	-
45359	5/8" RUBBER HOURGLASS	4	13	14
61150	5/8" X 10mm X 1.480 " SLEEVE	4	13	14
90-4247	C.V. SPACER	2	12	13
90-6717	HARDWARE PACK: CV Spacer	1	-	-

Part #	Description	Qty.	Illus.	Page
71-100451501000	10mm-1.5 X 45mm HEX BOLT GR. 10.9	12	12	13
73-01010940	10mm HARDENED FLAT WASHER	12	12	13
91-5732	CROSSMEMBER SKID PLATE	1	9	12
90-6705	HARDWARE PACK: Skid Plate	2	-	-
70-0501501800	1/2" X 1 1/2" HEX BOLT GR. 8	2	9	12
72-050100816	1/2" STOVER NUT G. C	2	9	12
73-05000034	1/2" SAE HARDENED FLAT WASHER	4	9	12
96-1505	WELD IN PLATE	1	2	8
Box 2 of 4-PN 51801/51801MX/51801MXR/51801BF/51801BFR-2				
90-4245	KNUCKLE: Drvr	1	-	-
90-4246	KNUCKLE: Pass	1	-	-
90-6782	HARDWARE PACK: Spare Tire Spacer	1	-	-
90-7089	WHEEL SPACER	1	-	-
Box 3 of 4-PN 51801/51801MX/51801MXR/51801BF/51801BFR-3				
91-5723	REAR CROSSMEMBER	1	5,7	10
90-6305	HARDWARE PACK: Rear Crossmembers	1	-	-
70-0625501800	5/8" X 6" GR. 8 HEX BOLT	2	5	10
72-062100816	5/8" USS GR. 8 STOVER NUT	2	5	10
73-06200042	5/8" HARDENED FLAT WASHER	4	5	10
91-8016	COMPRESSION STRUT	2	14	15
91-5781	COMPRESSION STRUT MOUNT	2	14	15
90-6263	HARDWARE PACK: Compression Strut	1	-	-
15-11148	BUSHING	8	14	15
90-2109	SLEEVE	4	14	15
90-6194	HARDWARE PACK: Comp Strut/Torsion Drop/ Square Bolt Plate	1	-	-
70-0504001800	1/2" X 4" GR. 8 HEX BOLT	4	14	15
73-05000034	1/2" SAE GR. 8 FLAT WASHER	8	14	15
73-05000100816	1/2" NYLOCK NUT	4	14	15
70-0501251800	1/2" X 1 1/4" GR. 8 HEX BOLT	2	14	15
70-0431251800	7/16" X 1 1/4" GR. 8 HEX BOLT	8	15	16
73-04300034	7/16" SAE GR. 8 FLAT WASHER	16	15	16
72-04300100816	7/16" NYLOCK NUT	8	15	16
70-0371251800	3/8" X 1 1/4" GR. 8 HEX BOLT	4	17	16
73-03700034	3/8" SAE GR. 8 FLAT WASHER	10	17,8	16,11
72-03700100816	3/8" NYLOCK NUT	6	17,8	16,11
90-1582	NUT PLATE: Compression Strut	2	8	11
91-5700	TORSION BAR DROP	2	15,16,17	16
90-1636	TORSION DROP ADAPTER: w/ 40 1/2" Torsion Bar Crossmember	2	16	16
90-1638	TORSION DROP ADAPTER: w/ 39 5/8" Torsion Bar Crossmember	2	16	16

Part #	Description	Qty.	Illus.	Page
90-6177	HARDWARE PACK: Torsion Drop	1	-	-
90-2011	SPACER: 1.0" X .05" X 1.5	2	17	16
15-11149	BUSHING	4	17	16
90-6298	HARDWARE PACK: Rear Brake Lines	1	-	-
90-1083	BRAKE LINE EXTENSION	1	-	-
90-1817	BRAKE LINE BRACKET: Rear	1	18	18
90-6299	HARDWARE PACK: Rear Brake Lines	1	-	-
70-0311001500	5/16" X 1" GR.5 HEX BOLT	2	18	18
72-03100100512	5/16" NYLOCK NUT	2	18	18
73-03100030	5/16" SAE FLAT WASHER	4	18	18
91-5705	REAR BUMP STOP SPACER	2	20	19
90-6223	HARDWARE PACK: Rear Bump Stop	1	-	-
70-0371251800	3/8" X 1 1/4" GR. 8 HEX BOLT	4	20	19
72-037100816	3/8" USS STOVER NUT	4	20	19
73-03700034	3/8" SAE GR. 8 WASHER	8	20	19
95-401	4" REAR LIFT BLOCK	2	19	18
13-90347	U-BOLT: 5/8"-18 x 2.625" x 14.00"	4	19	18
20-65471	HARDWARE PACK: 5/8" High Nuts	1	19	18
51255	HARDWARE PACK: Driveshaft Shim Kit	1	-	-
90-4056	1" X 1 1/2" X 8" ALUMINUM SHIM BLOCK	1	21	19
90-1080	3/8" X 1 1/2" X 8" SHIM	2	-	-
90-1081	1/4" X 1 1/2" X 8" SHIM	2	-	-
90-1082	1/8" X 1 1/2" X 8" SHIM	2	-	-
90-6216	HARDWARE PACK: Driveshaft Shim Kit	1	-	-
70-04332501800	7/16" X 3 1/4" NC BOLT	2	21	19
73-04300042	7/16" HARDENED FLAT WASHER	4	21	19
72-043100816	7/16" NYLOCK NUT	2	21	19
91-5753	FRONT BUMP STOP BRACKET: Drvr	1	11	13
91-5757	FRONT BUMP STOP BRACKET: Pass	1	11	13
90-6223	HARDWARE PACK: Front Bump stop	1	-	-
70-0371251800	3/8" X 1 1/4" GR. 8 HEX BOLT	4	11	13
72-037100816	3/8" USS STOVER NUT	4	11	13
73-03700034	3/8" SAE GR. 8 WASHER	8	11	13

Box 4 of 4-PN 51801-4

922010	9000 SERIES FRONT SHOCKS	2	-	-
930001	9000 SERIES REAR SHOCKS	2	-	-

Box 4MX of 4-PN 51801MX-4

MX6168	MX-6 SERIES FRONT SHOCKS	2	-	-
MX6167	MX-6 SERIES REAR SHOCKS	2	-	-

Part #	Description	Qty.	Illus.	Page
OR Box 4BF of 4 PN # 51801BF-4				
FX6300	FRONT FOX EMULSION SHOCK	2	-	-
FX6301	REAR FOX EMULSION SHOCK	2	-	-
BOX 922010B/ 930001B (K1084T)				
922010B	FRONT SHOCK	2	-	-
930001B	REAR SHOCK	2	-	-
BOX PR2001/ BOX PR2006 (K1084M)				
PR2001	REAR SHOCKS	2	-	-
PR2006	FRONT SHOCKS	2	-	-

Part #	Description	Qty.	Illus.	Page
--------	-------------	------	--------	------

Warning!

Be extremely careful when unloading or loading the torsion bars on your vehicle. There is a tremendous amount of stored energy! Keep your hands and body clear of the adjuster arm assembly and puller tool in case anything slips or breaks!

Special Equipment

- ⇒ A special removal tool is required for safe removal and installation of the torsion adjuster arms. This special puller can be purchased from your local GM dealer (Tool #J36202) or from the Kent Moore Tool Group in Roseville, MI. (800) 345-2233 or (313) 774-9500 (Part #J22517-C). You may be able to rent these at your local parts store. Please refer to your GM service manual for more information.
- ⇒ A welding machine and someone with welding experience is required for a small portion of this installation.
- ⇒ Front end and head light realignment is necessary!
- ⇒ Speedometer and ABS recalibration will be necessary if larger tires (10% more than stock diameter) are installed

Wheel and Tire Information:

- ⇒ **Due to differences in manufacturing, dimensions and inflated measurements, tire and wheel combinations should be test fit prior to installation. Tire and wheel choice is crucial in assuring proper fit, performance, and the safety of your Pro Comp equipped vehicle. For this application, we recommend a 16" or 17" wheel not to exceed 9" in width with a maximum backspacing of 4 5/8" can be used. Also an 18" wheel not to exceed 9" in width with a maximum backspacing of 5" can be used. A quality tire of radial design, not exceeding 35" tall X 12.5" wide is also recommended. Please note that the use of a 35" X 12.5" tire may require trimming of the front valence. Violation of these recommendations will not be endorsed as acceptable by Pro Comp Suspension and will void any and all warranties either written or implied.**

IMPORTANT!: This kit cannot be used in conjunction with Factory wheels or the factory spare on the front suspension

Equipment Available from your Pro Comp Distributor!

- 51214B: Dual Shock Kit**
- MX6141R: Rear MX-6 Reservoir Shocks**
- FX6505R: Rear FOX Reservoir Shocks**
- 72400: Traction Bars**
- 71200: Traction Bar Mounting Kit**
- 51101: Skid Plate Kit**
- 51247: CV Front Driveshaft Kit– Vehicles equipped with Borg Warner transfer case 4482**
- 95-300B: Block kit for 1-piece driveshaft**
- 51810: Exhaust crossover kit 1500/2500 w/ 6.0L engine**

Also, Check out our outstanding selection of **Pro Comp** tires to compliment your new installation!

Introduction:

- ◆ **This installation requires a professional mechanic!**
- ◆ We recommend that you have access to a GM service manual for your vehicle to assist in the disassembly and reassembly of your vehicle. It contains a wealth of detailed information.
- ◆ Prior to installation, carefully inspect the vehicle's steering and driveline systems paying close attention to the tie rod ends, ball joints, wheel bearing preload, pitman and idler arm. Additionally, check steering-to-frame and suspension-to-frame attaching points for stress cracks. The overall vehicle must be in excellent working condition. Repair or replace all worn or damaged parts!
- ◆ Read the instructions carefully and study the illustrations before attempting installation! You may save yourself a lot of extra work.
- ◆ Check the parts and hardware against the parts list to assure that your kit is complete. Separating parts according to the areas where they will be used and placing the hardware with the brackets before you begin will save installation time.
- ◆ Check the special equipment list and ensure the availability of these tools.
- ◆ Secure and properly block vehicle prior to beginning installation.
- ◆ ***ALWAYS*** wear safety glasses when using power tools or working under the vehicle!
- ◆ Use caution when cutting is required under the vehicle. The factory undercoating is flammable. Take appropriate precautions. Have a fire extinguisher close at hand.
- ◆ Foot pound torque readings are listed on the Torque Specifications chart at the end of the instructions. These are to be used unless specifically directed otherwise. Apply Loctite® retaining compound where specified.
- ◆ ***Please note that while every effort is made to ensure that the installation of your Pro Comp lift kit is a positive experience, variations in construction and assembly in the vehicle manufacturing process will virtually ensure that some parts may seem difficult to install. Additionally, the current trend in manufacturing of vehicles results in a frame that is highly flexible and may shift slightly on disassembly prior to installation. The use of pry bars and tapered punches for alignment is considered normal and usually does not indicate a faulty product. However, if you are uncertain about some aspect of the installation process, please feel free to call our tech support department at the number listed on the cover page. We do not recommend that you modify the Pro Comp parts in any way as this will void any warranty expressed or implied by the Pro Comp Suspension company.***
- ◆ This kit works on vehicles manufactured after 8/2000 with large tie rod ends.
- ◆ Models produced before 8/1/2000 will be required to upgrade to the later model large tie rod ends that are found on models produced after 8/1/2000.
- ◆ Exhaust modification may be required to install this system and can be performed by a qualified muffler shop.
- ◆ No special driveshaft is required with this kit. Vehicles with a one piece rear driveshaft may experience driveline vibration.
- ◆ This kit does not work on vehicles with rear steering.
- ◆ This kit does not fit standard cab models.
- ◆ This kit will not work on vehicles equipped with factory electronic or air ride suspension systems.
- ◆ This system is designed to fit both 2wd and 4wd vehicles. On any 2wd installations disregard any steps involving the front differential and the C.V. shafts.
- ◆ Verify the differential fluid is at the manufacturers recommended level prior to the installation of the kit. The installation of this kit will reposition the differential and the fill plug hole may be in a different position. *(For example, if the manufacturer recommends 3 quarts of fluid, make sure the differential has 3 quarts of fluid).* Check your specific manual for the correct amount of fluid.

Front Installation

1. Ensure that your work space is of adequate size and the work surface is level. Measure and record the distance from the center of each wheel to the top of its fender opening.

LF: _____ RF: _____

LR: _____ RR: _____

2. Place the vehicle in neutral. Place your floor jack under the front cross member and raise vehicle. Place jack stands under the frame rails behind the front wheel wells and lower the frame onto the stands. Remove the jack and place the vehicle back in gear, set the emergency brake, and place blocks both in front and behind the rear wheels. Remove the negative cable from the battery.

3. Remove any skid plates or debris shields from the vehicle. Save the hardware for reinstallation.
4. Measure the torsion bar adjusting screw depth and record this dimension for later use on reassembly. See ILLUSTRATION 1.
5. Remove the torsion bar adjusting screw. Apply

LEFT: _____ RIGHT: _____

a small amount of lubrication grease to the puller threads and the puller shaft-to-adjuster arm contact point. Load the puller and torsion adjuster arm until the adjuster nut can be removed from the cross member. Release the puller to unload the torsion bar. With the bar unloaded, slide it forward into the lower control arm until the adjuster arm falls free.

NOTE: *If the bar seems stuck, use a hammer and punch through the hole in the rear of the cross member to dislodge it.*

6. Repeat this procedure on the other side of the vehicle.
7. Remove the torsion bar cross member by unbolting it from the frame.
8. Remove the torsion bars from the lower A-arms.
9. Unbolt the sway bar link ends from the sway

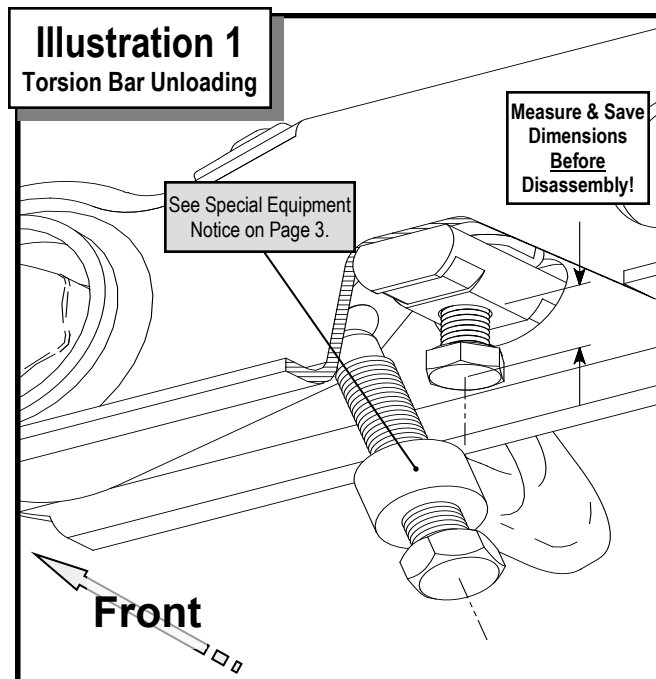

bar and lower control arm. Discard the sway bar links and bushings.

10. Remove the front shock absorbers.
11. Remove the **OE** lower rubber bump stops from the frame. Save for reinstallation.
12. Remove front factory differential skid plate and splash shield. These items will not be reinstalled.
13. Remove the nut from the **OE** tie rod end. Using an appropriate removal tool, remove the tie rod end from the spindle.
14. Remove the brake hose bracket from the top of the **OE** knuckle. Unplug the ABS brake connection from the frame and control arm.
15. Remove the brake calipers from the rotor and secure them clear of the work area. Secure calipers up with wire so they do not hang.
CAUTION!: *Do not suspend them by the brake lines! Damage will result!*
16. Remove the front rotors from the front hub.
17. Remove the dust cap and the axle retaining nut.
18. Unbolt the **(4)** bolts holding the hub flange to the knuckle. Remove the hub and O-ring and save for reinstallation.
19. Support the knuckle and loosen the upper ball joint nut from the knuckle and separate using the appropriate tool.

20. Support the knuckle and loosen the lower ball joint nut from the knuckle and separate using the appropriate tool.
21. Remove the (6) retaining bolts from each CV joint. Carefully remove the CV axle from the side of the vehicle you are currently working on.
NOTE: Be extra cautious with the CV boots. DO NOT damage them!
22. Support the lower A-arms with your floor jack and remove the upper and lower ball joint nuts. Remove the knuckle from the vehicle.
23. Support the lower A-arm with your floor jack and remove the lower A-arm pivot bolts. Carefully remove the lower A-arms from the vehicle.
24. Disconnect the front drive shaft from the front differential and secure it clear of the work area. Tape the U-joint caps in place.
25. Disconnect the differential vent line and any electrical control wire harnesses that may be present. Secure these clear of the work area.
26. Remove the stock differential rear crossmember and discard.

27. Support the differential with your floor jack. Unbolt and lower the differential to the ground and move it clear of the work area.

NOTE: Some models may require performing step 28 first in order to remove the differential assembly.

28. Using a suitable cutting tool, (abrasive cutoff wheel, Sawz-all, etc.) cut the driver side, rear differential bracket as shown in ILLUSTRATION 2. Follow the dimensions shown closely!

NOTE: It may be easier to trim the differential bracket off in 2 smaller incremental cuts. It is very important that you measure carefully. If you cut too much, the lower drop will not fit. If you cut too little, you may have to grind material from the differential to clear the adapter.

29. Clean the cut edges of all undercoat material and any oxidation that may be present. Place the weld in plate (96-1505) into position as shown. Trim excess material if needed. See ILLUSTRATION 2.

30. Tack the weld in plate (PN 96-1505) to the back of the pocket. **DO NOT** finish welding until the front differential has been reinstalled to ensure there is adequate clearance between the differential and the frame. See ILLUSTRATION 2.

31. Cut the upper differential mount ear from the differential case as shown in ILLUSTRATION 3. Leave 1/4" of material above the case.

CAUTION: Be very careful while cutting. DO NOT CUT INTO THE CASE!

32. Install the urethane bushings (15-11326) and sleeve (90-2109) from hardware pack (90-6657), into the driver side differential bracket (91-5708). See ILLUSTRATION 4.

33. Rotate the front differential until the case bolt heads are oriented up. Carefully remove the (5) factory bolts from the differential as shown in ILLUSTRATION 4.

NOTE: You will probably notice some differential oil seeping from the area where the bolts are removed. This is normal and not something to worry about.

IMPORTANT!: If you do not stand the differential as directed, you will see a LOT more oil on your floor.

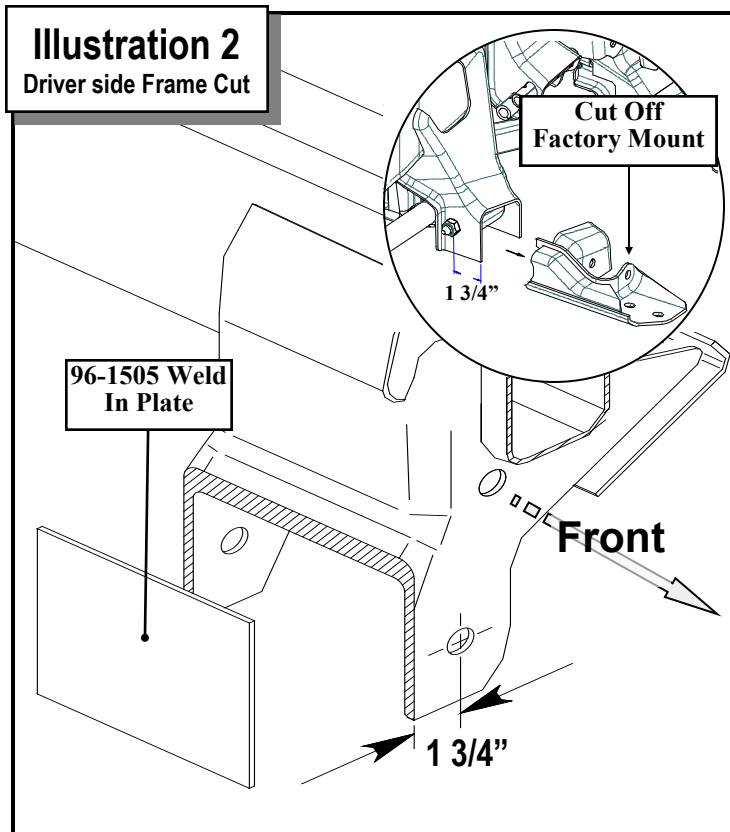

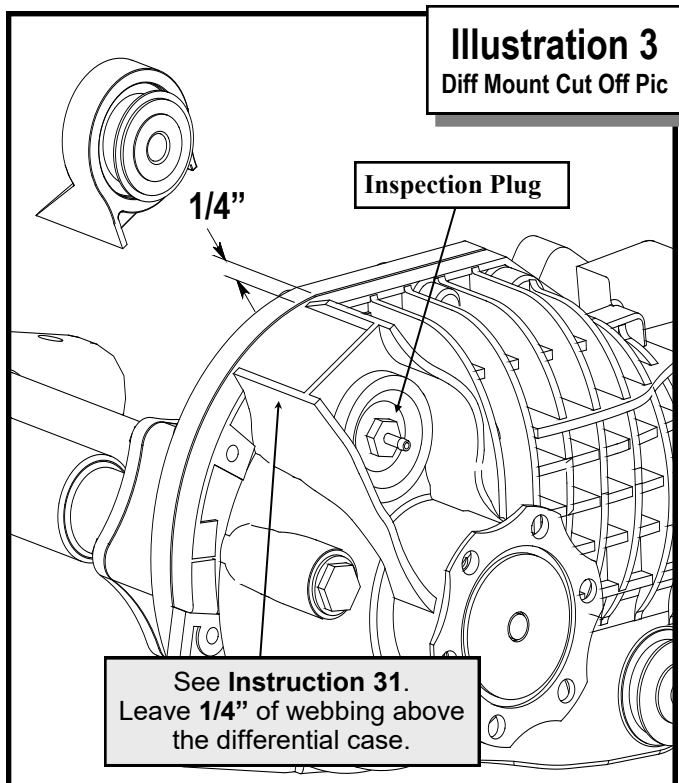

34. Place the driver side differential bracket (**91-5708**) as shown with the bushing eye to the top side of the housing. Secure using the (5) supplied **10mm X 60mm** hardware (bolts, washers) from hardware pack (**90-6718**). Torque these fasteners to **30 ft./lbs.** See ILLUSTRATION 4.
35. Install the rear crossmember (**91-5723**) into the factory lower control arm pockets using the **OE** bolts and hardware. Install the bolts with the heads to the front of the vehicle. Leave loose at this time. See ILLUSTRATION 5.
36. Install the passenger side differential bracket (**91-5711**) to the bottom of the **OE** frame mount. Be sure the notch on the bracket is to the top and facing toward the front of the vehicle. Secure using the previously removed hardware. See ILLUSTRATION 6. Torque the **OE** hardware to **70 ft./lbs.**
37. Place the differential housing into the rear crossmember (**91-5723**) using the previously removed **OE** hardware on the driver side rear

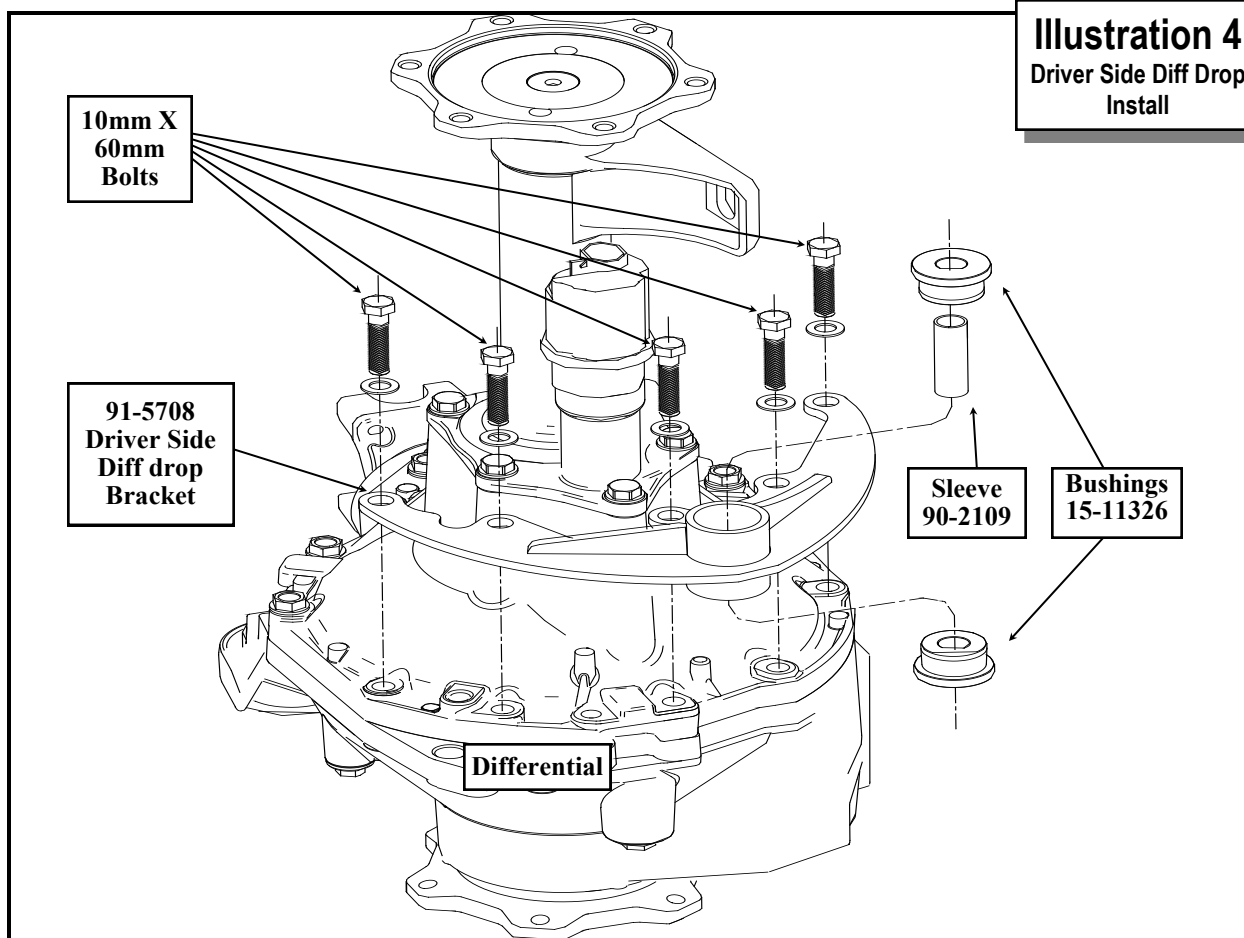

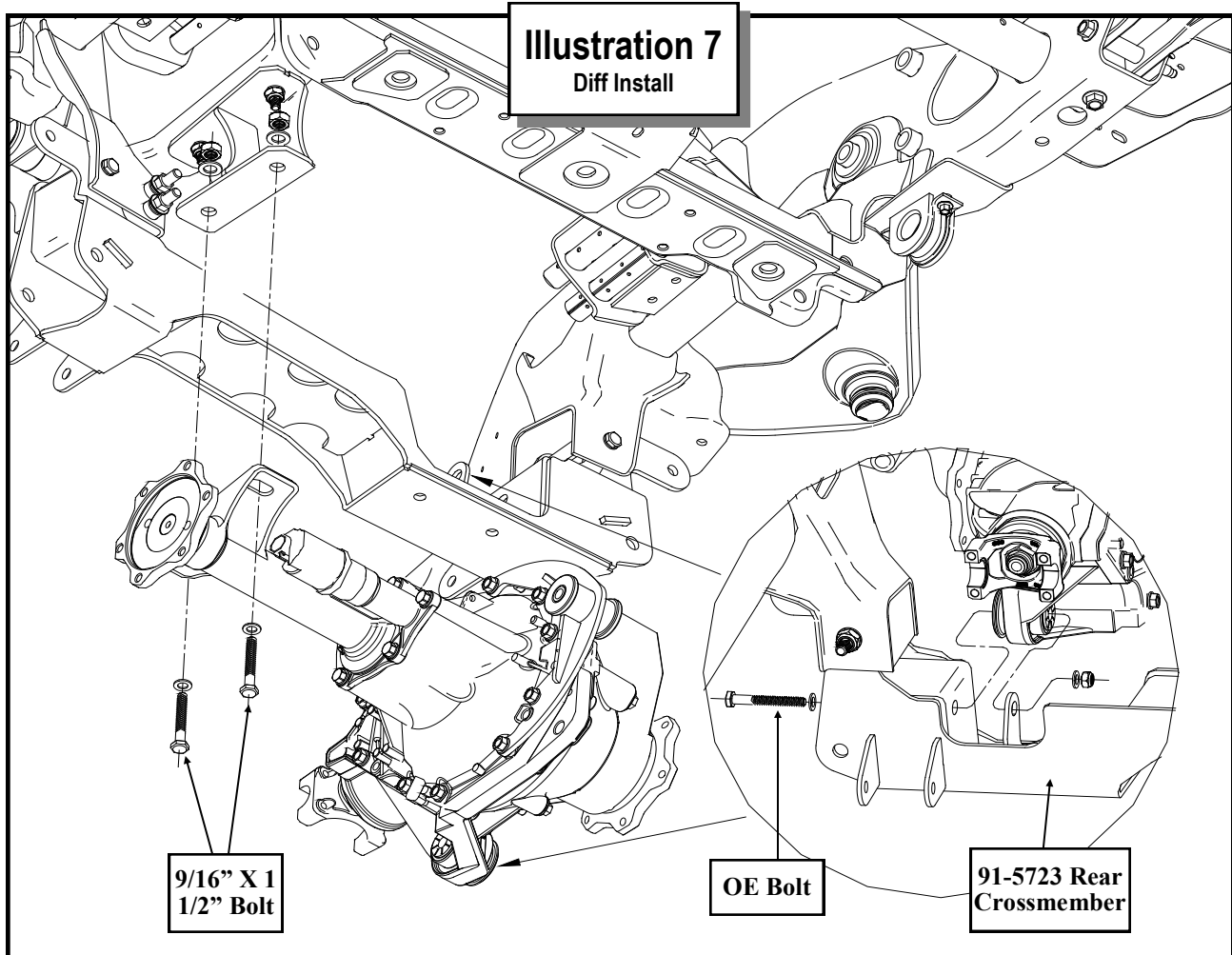
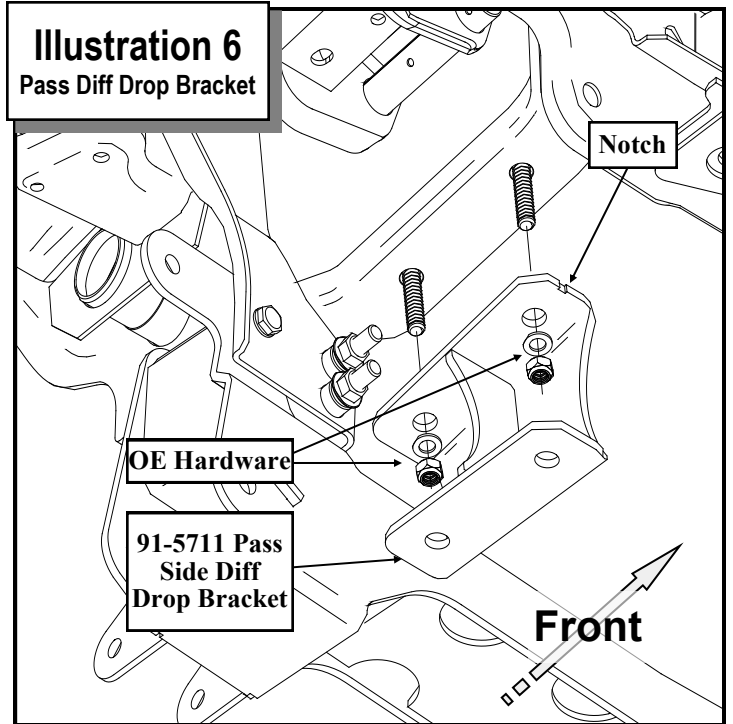
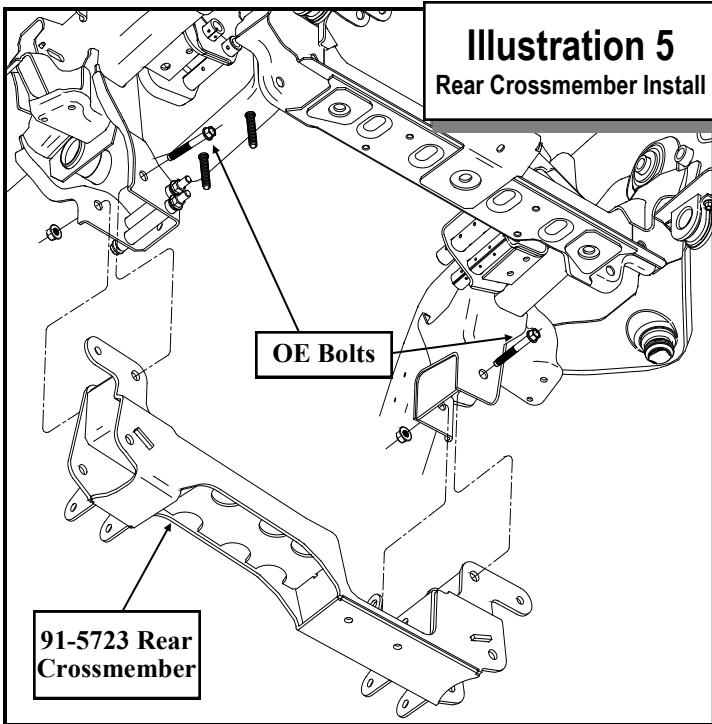

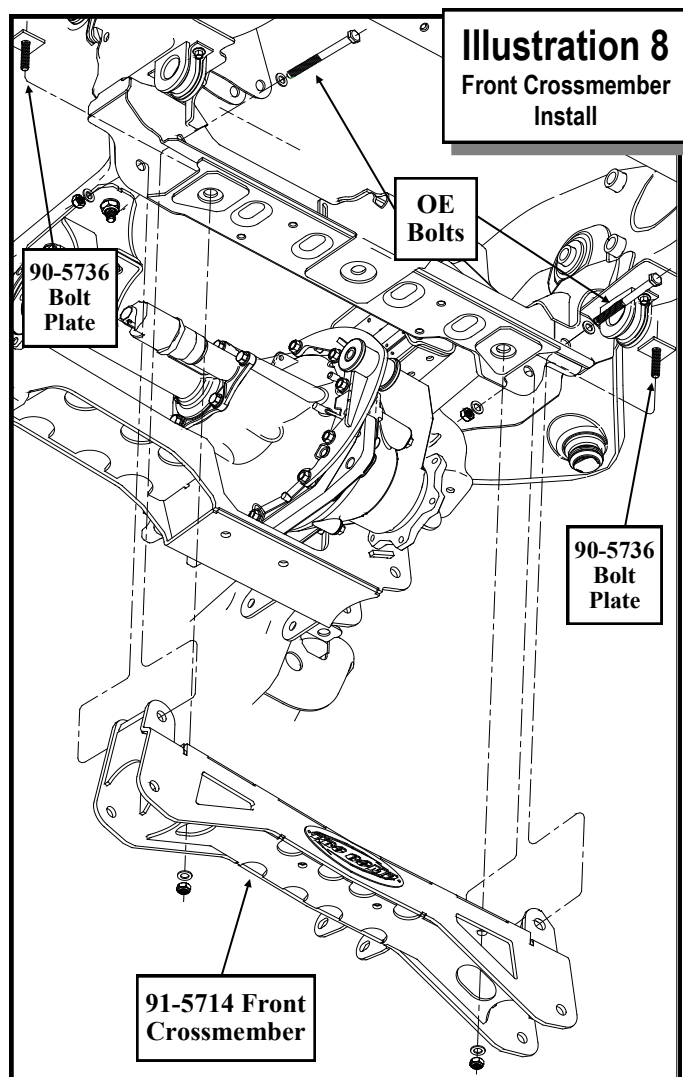

mount. Use the supplied 9/16" X 1 1/2" bolts and hardware on the passenger side. leave loose at this time. See ILLUSTRATION 7.

38. Insert the square bolts plates (90-5736) into the OE front control arm frame crossmember and through the outer holes on the top of the front crossmember (91-5714). Install the front crossmember (91-5714) into the lower control arm pockets using the OE previously removed bolts, hardware, 3/8" bolt plate washers and nuts from pack (90-6194). Leave loose at this time. See ILLUSTRATION 8.
39. Install the driver differential mount (91-5708) into the front crossmember tabs. Install the crossmember skid plate (91-5732) around the differential housing bushing using 1/2" X 4 1/2" bolt and hardware. Leave loose at this time. See ILLUSTRATION 9.

Illustration 8
 Front Crossmember
 Install

40. Using the differential drop extension pack (90-6189) fit the new hose to the differential. Place the supplied plug in the end of the tube and connect the factory tube to it. Reinstall the electronic wiring to the differential. You may have to reroute these for proper fit.

41. Secure the rear of the crossmember skid plate to the rear crossmember using the 1/2" X 1 1/2" bolt and hardware. See ILLUSTRATION 9.

42. Install the lower control arms into the new crossmember mounting pockets with the crossmember support tubes (91-8020) placed over the pivot bolts between the crossmembers. Secure using the 5/8" X 5" (front) and 5/8" X 6" (rear) bolts and hardware. Do not torque the bolts until the vehicle is on the ground. See ILLUSTRATION 10.

43. Carefully check the entire differential installation for adequate clearance. Pay particular attention to the clearance between the front differential and the previously installed weld plate.

CRITICAL NOTE: A minimum of 3/16" between these components is mandatory. Insufficient clearance will result in an annoying rattle at the least and component failure at the worst.

44. Carefully remove the differential assembly and finish welding the weld in plate (96-1505). Paint the welded areas to prevent rust. After welding the plate, clean the area thoroughly and paint the exposed metal with a good quality paint.

45. Carefully Reinstall the differential assembly and torque the following differential and crossmember bolts: Driver side 1/2" differential bushing bolts to 70 ft./lbs, Passenger side 9/16" differential bracket bolt to 70 ft./lbs, OE Crossmember frame pocket bolts to 105 ft./lbs, Front crossmember 3/8" square bolt plates to 25 ft./lbs, Rear 1/2" Crossmember skid plate bolts to 50 ft./lbs. Recheck all bolts on the front end for proper torque before proceeding to next step.

46. Install the two front bump stop drop brackets (91-5753 Drvr and 91-5757 Pass) to the rear crossmember using 1/2" X 1 1/2" bolts and hardware. Attach the bump stop drop brackets to the frame using the 3/8" X 1 1/4" bolts and hardware. See ILLUSTRATION 11. Torque the 3/8" hardware to 20 ft./lbs and 1/2" hardware to 35 ft./lbs. Attach the previously re-

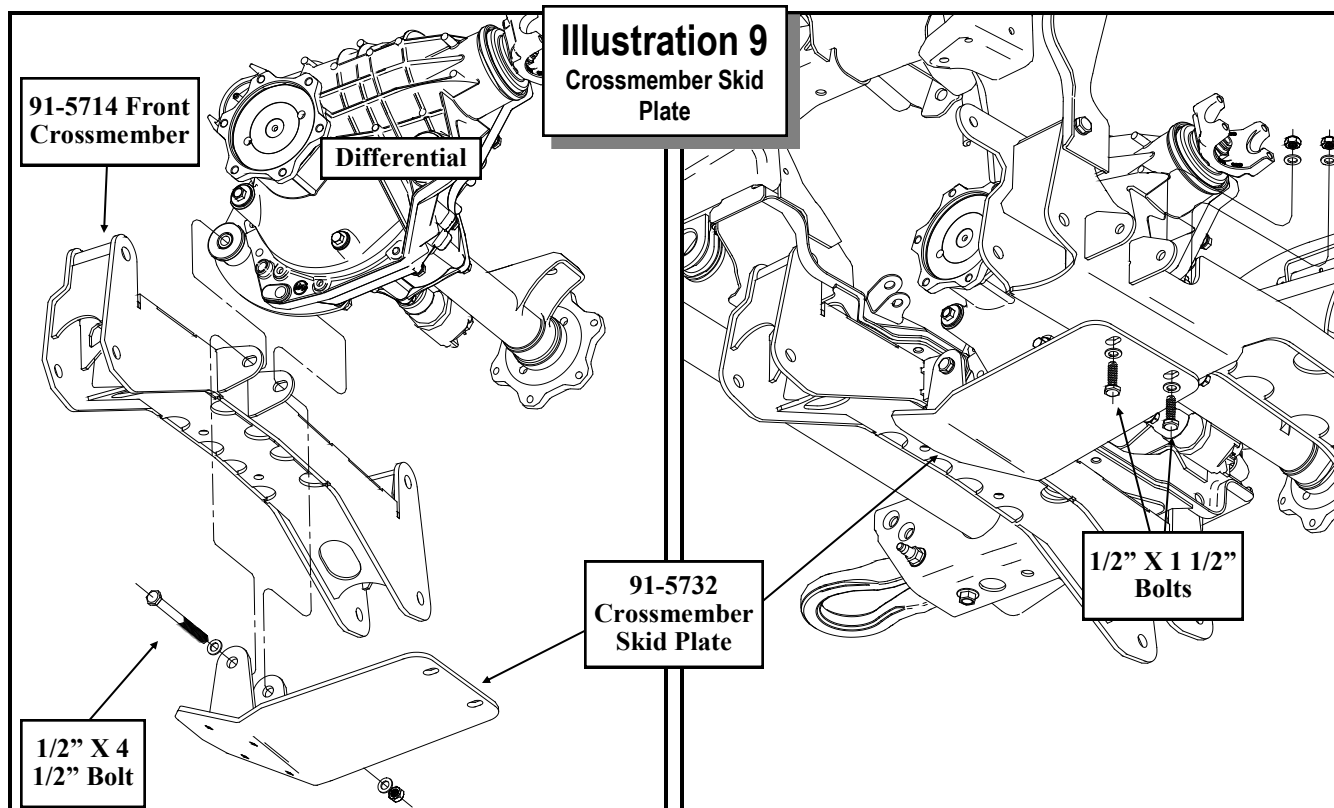

moved OE bump stops to the bump stop drop brackets and torque to **15** ft./lbs.

NOTE: The bump stops will be engaged with the A-arms at ride height.

47. Assemble the new steering knuckles (90-4245 drvvr and 90-4246 pass) using the previously removed OE hub bearing assemblies and O-

rings. Apply thread lock compound to the OE hardware. Torque the flange bolts to **130** ft./lbs.

NOTE: Be sure the O-ring is placed in it's proper position while installing the hub.

48. Install the assembled knuckle to the upper and lower ball joints using the OE nuts. Torque the upper ball joint to **35** ft./lbs. and the lower ball joint to **70** ft./lbs.

49. Turn the tie rod ends 180 degrees. Reattach the tie rod ends to the new knuckles using the previously removed OE nuts. Torque the factory nut to **30** ft./lbs.

50. Insert the CV shaft into the steering knuckle and reinstall the axle shaft washer and retaining nut. Be sure to use thread locker on the retaining nut. Torque the axle nut to **150** ft./lbs.

51. Place one of the CV spacers (90-4247) between the front differential drive flange and the CV. Use the **10mm X 45mm** bolts and washers provided in hardware pack (90-6717) through the CV and spacer and into the differential drive flange. Be sure to use thread lock compound on the bolts. See ILLUSTRATION 12. Torque the CV spacer bolts to **55** ft./lbs. in a criss-cross pattern.

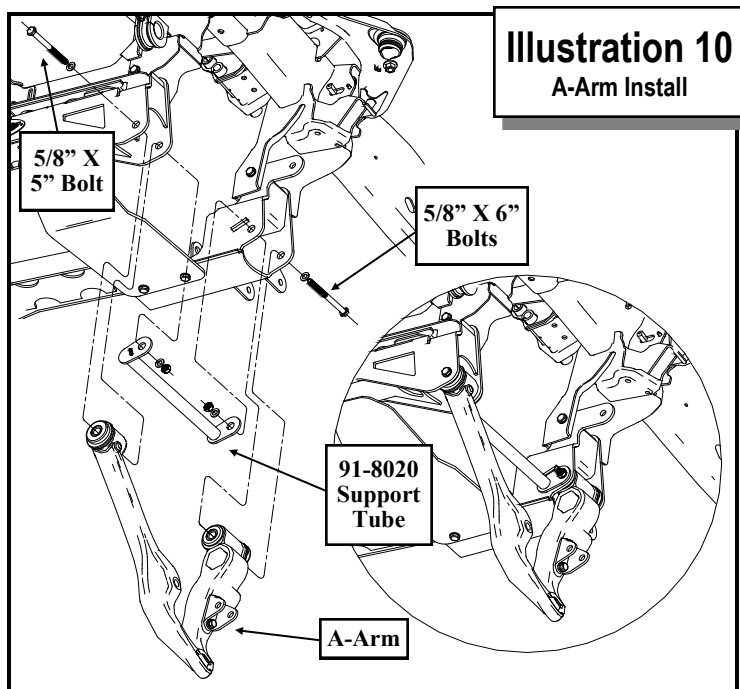

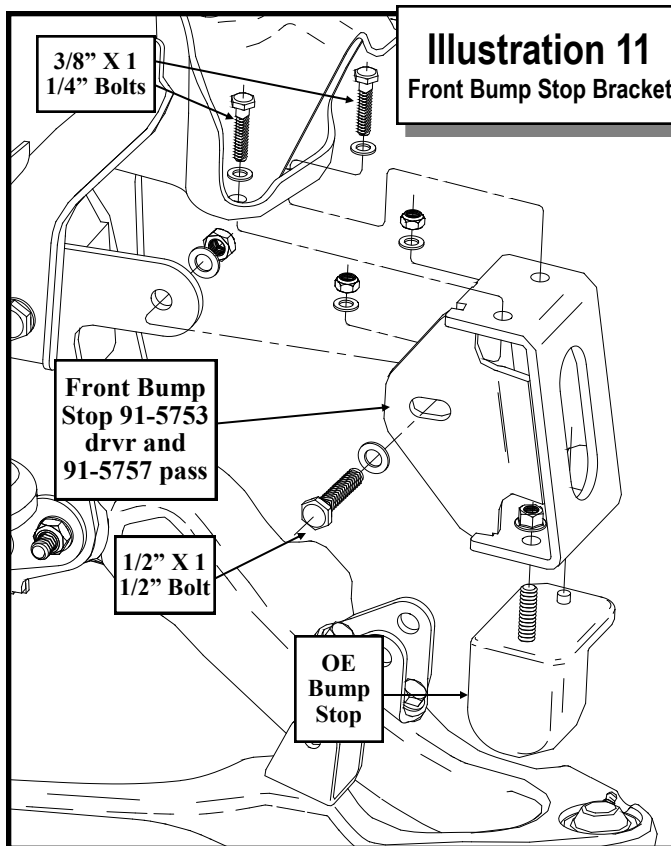

Illustration 11
Front Bump Stop Bracket

54. Slide the brake hose clamp down and attach it to the top hole in the back of the steering knuckle using the previously removed **OE** bolt. Torque the bracket hardware to **10** ft./lbs.
55. If you have ABS brakes, attach the ABS cable to the knuckle and upper control arm with zip ties. Check to make sure that the brake hose and ABS line is routed as to allow full turning radius to the steering without tire or suspension component contact.
56. Reattach the driveshaft to the differential yoke using the previously removed **OE** hardware. Torque U-joint straps to **19** ft./lbs.
57. Assemble the sway bar end links (**91-8018**) using the supplied bushings (**45359**) and sleeves (**61150**). See ILLUSTRATION 13.
58. Unbolt and remove the sway bar from the vehicle. Flip the bar upside down and reattach it to the **OE** mounting position.
59. Install the upper sway bar upper mount (**90-5738**) to the sway bar using the **5/8" X 2"** bolts, mount plate (**90-5739**) and hardware. See ILLUSTRATION 13.

52. Install the new Pro Comp shock absorbers (**922010, MX6168, FX6300**) to the front installation. Torque the upper stem bushing to **15** ft./lbs. and the lower bolt to **35** ft./lbs.
53. Reinstall the brake rotors and brake calipers. Torque the calipers to the knuckle to **70** ft./lbs. using the previously removed **OE** hardware. Be sure to use thread locker on these bolts.

- NOTE: No washer is used on top of the bracket.**
60. Install the lower sway bar mount (**90-5730**) to the A-Arm using the **9/16" X 1 1/2"** bolts and hardware. See ILLUSTRATION 13.
 61. Install the end links to sway bar mounts using the **3/8" X 2 1/2"** bolts and hardware. See ILLUSTRATION 13.

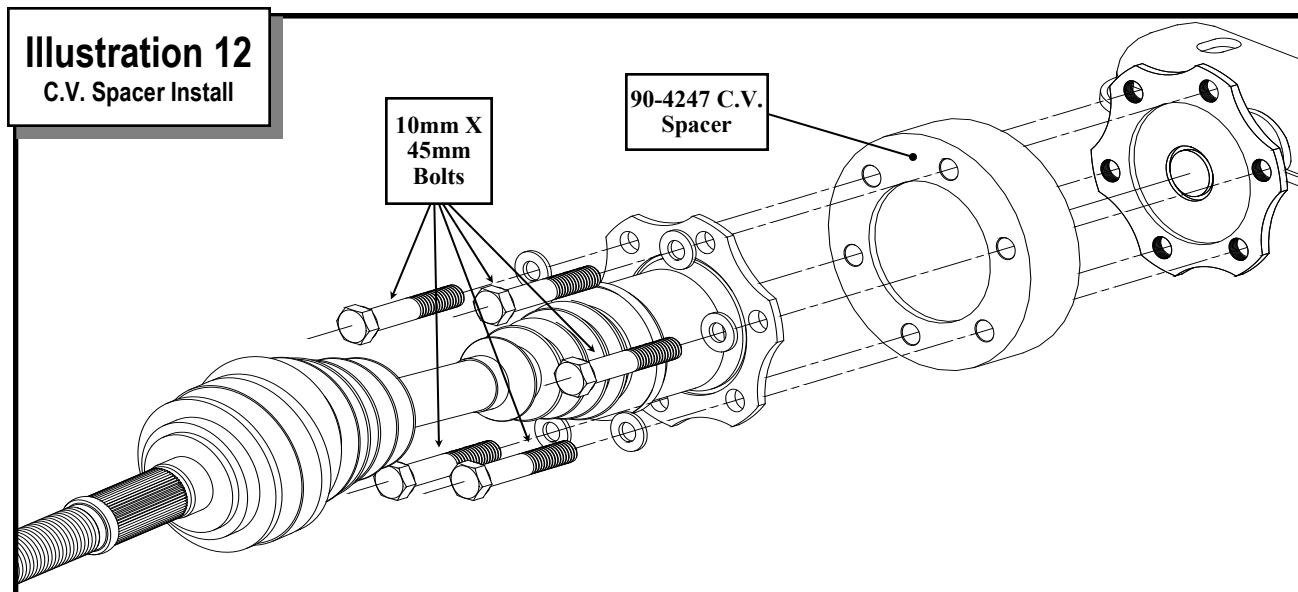
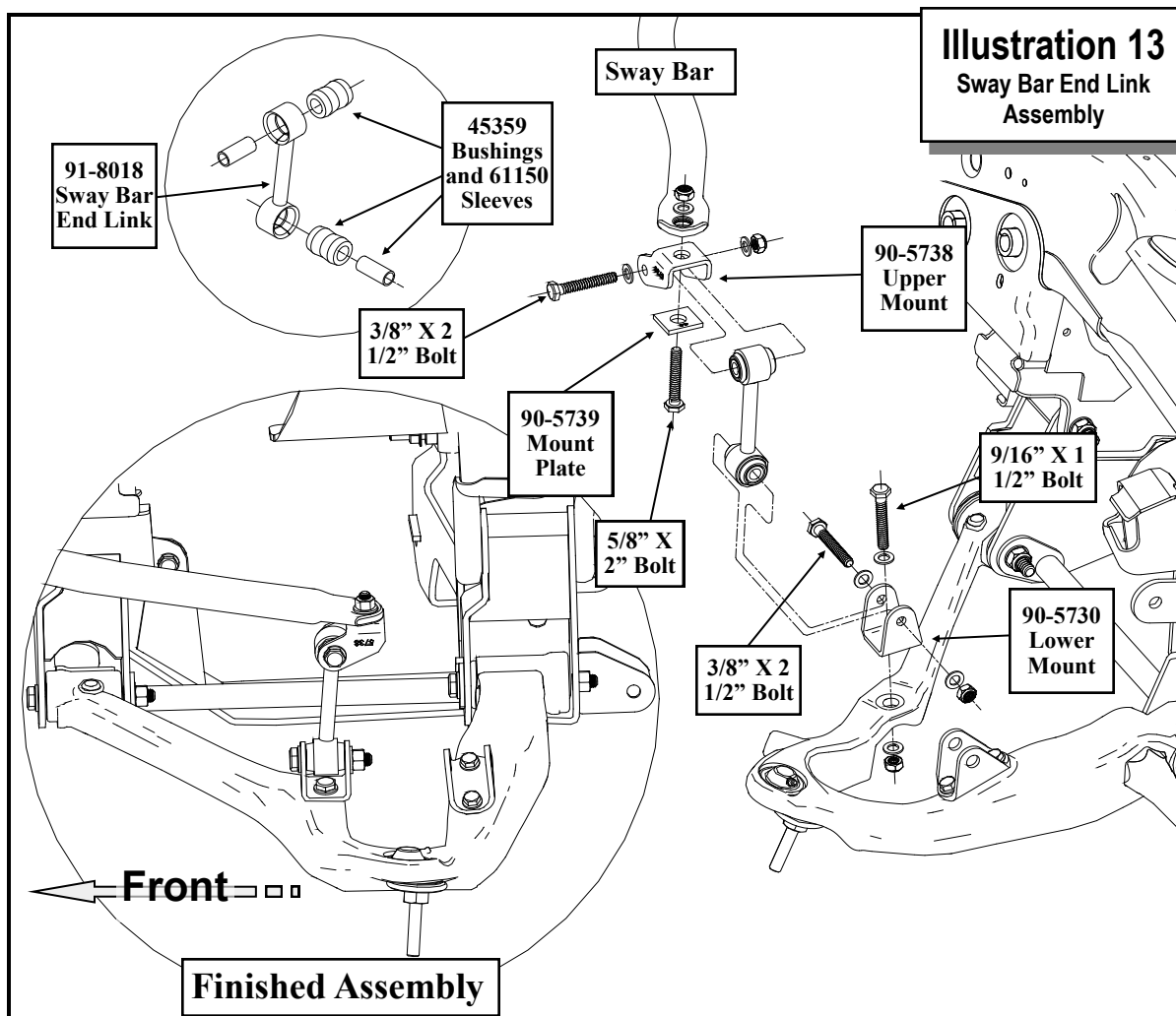

Illustration 12
C.V. Spacer Install



NOTE: The sway bar end link will be angled toward the rear of the vehicle.

62. Torque the **5/8"** sway bar end link hardware to **135** ft./lbs. Torque the **9/16"** sway bar end link hardware to **95** ft./lbs. Torque the **3/8"** sway bar end link hardware to **45** ft./lbs.
63. Recheck all bolts on front end for proper torque before proceeding to next step.
64. Assemble the compression strut assemblies (**91-8016**) as shown in ILLUSTRATION 14. Use the urethane bushings (**15-11148**) and sleeves (**90-2109**) from parts pack (**90-6263**).
65. Position the compression struts (**91-8016**) into the tabs on the rear cross member using the supplied **1/2" X 4"** bolts and hardware. See ILLUSTRATION 14.
66. Attach the compression strut mounts (**91-5781**) to the other end of the struts, with the flair of the brackets to the rear of the vehicle. For vehicles with Allison transmissions place the bushing eye in the forward position. For vehicles with vehicles with 4L80-E transmissions place the bushing eye in the rear position. Secure using **1/2" X 4"** bolts and hardware. Leave loose at this time. See ILLUSTRATION 14.
67. Swing the mount up to the bottom of the cross-member. Using the compression strut mounts (**91-5781**) as a guide, mark and drill the new mounting holes using a **1/2"** drill bit. See ILLUSTRATION 14.

NOTE: Some models may require cutting of the transfer case skid plate to allow the strut mount to become flush with the bottom of the crossmember.
68. Rotate the struts back up and secure the compression strut mounts (**91-5781**), to the newly drilled holes in the crossmember, using the supplied **1/2" X 1 1/4"** bolt and nut plate (**90-1582**) See ILLUSTRATION 14. Torque the compress-

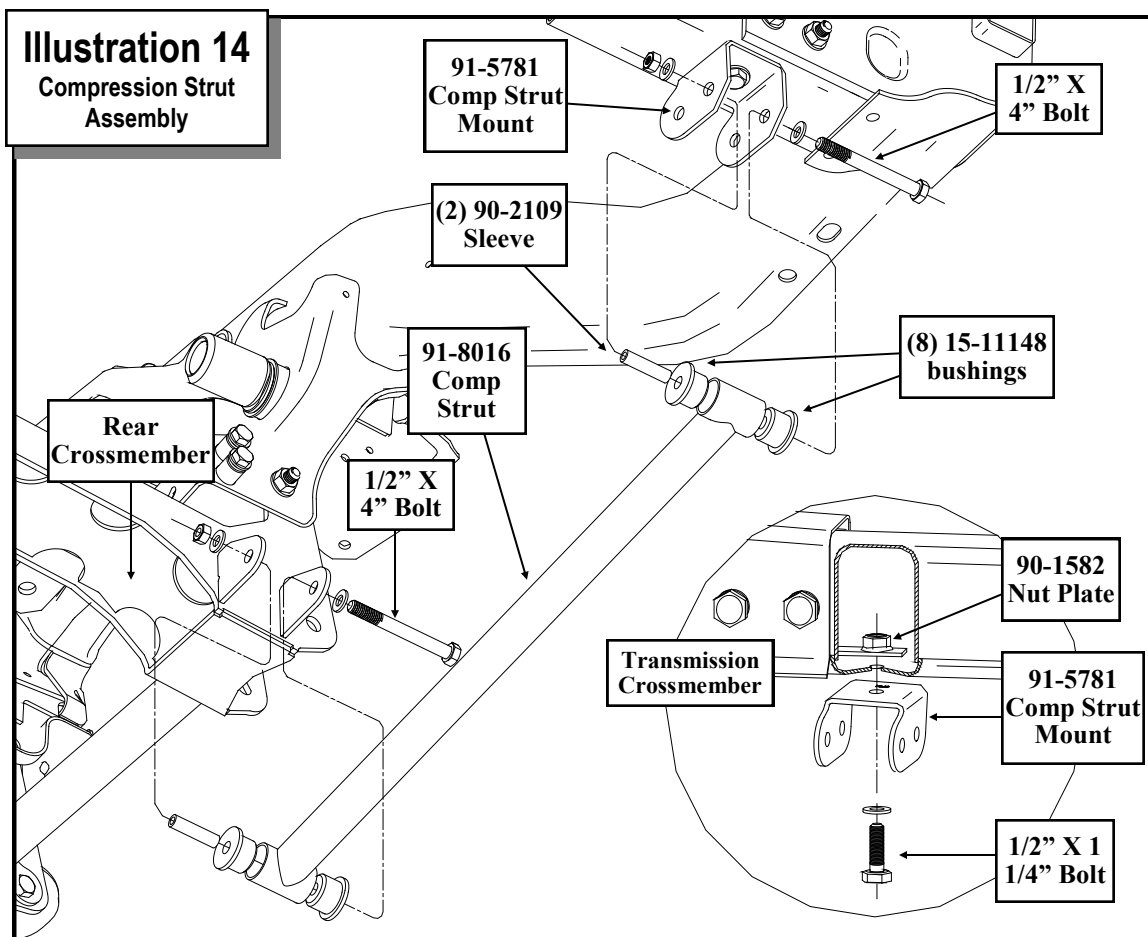

sion strut hardware to **50** ft./lbs.

69. Install the universal torsion bar cross member drops by locating part (91-5700) in place as shown in ILLUSTRATIONS 15. Clamp them in place to the bottom and face of the frame rail. The location is determined by centering the drop bracket holes on either side of the OE mounting rivet heads as shown in the detail view. Drill the four mounting holes per side (top and bottom) using a 7/16" drill bit. Using the supplied 7/16" X 1 1/4" bolts, fasten the drops to the frame rails leaving them slightly loose.

NOTE: When located properly the new torsion drop bushing eye will be located directly below the OE bushing eye.

70. From the factory, there are at least two different configurations for the torsion drop brackets. Included in the kit are adapters made specifically for these differences. The primary difference between the two pieces is the width of the cross member. Models with a torsion cross member width of 39 5/8" (bolt center to bolt center) will use torsion drop adapters (90-1638). Models

with a torsion cross members with a width of 40 1/2" will use (90-1636). They are mounted to the universal adapters (91-5700) using four 3/8" X 1 1/4" bolts from parts pack (90-6223). See ILLUSTRATION 16.

71. Torque the torsion bar drop hardware according to the torque chart on page 20.
72. Install the torsion bars into the front A-arms. Again, be very careful to install them with the same orientation that they were removed (i.e. left front to left front, right front to right front!).
73. Install the torsion bar crossmember as shown in ILLUSTRATION 17. Torque the OE cross-member bolts to **70** ft./lbs.
74. Install the torsion bars into the torsion bar crossmember. **Reset the torsion bar preload bolts using the measurements previously taken.**
75. Check the fluid in the front differential and fill if needed with factory specified differential oil.

NOTE: Due to it's new position, the differ-

ential will accept additional fluid. Use the inspection plug, not the fill hole to add additional fluid. See ILLUSTRATION 3. Remove the inspection plug and fill the differential with fluid up to about a 1/2" below the inspection plug hole. **DO NOT** overfill the differential or it will leak out the vent tube.

76. Lower the vehicle to the ground. Torque the lug nuts according to the wheel manufacturers recommendations. If the wheel contacts the front or rear of the wheel well some trimming will be necessary.

NOTE: Remove OE rotor/drum retaining clips from wheel studs before installing the wheels.

77. With the vehicle on the ground torque the lower A-arm bolts to 105 ft. lbs.

78. With the front wheels installed cycle the steering from lock to lock to check to make sure the front wheels have enough clearance in the wheel well. Check the caliper banjo fitting to ensure the line has the proper amount of slack. On both sides of the vehicle, check the routing of the brake lines and the ABS wire harnesses. There must be no pinching, rubbing, or stretching of either component. Use zip ties to secure these items to the steering components. At full droop, cycle the steering from lock to lock while observing the reaction of these components. Reposition them if needed.

79. On electronic stability control equipped vehicles, center the steering wheel and lock it in place. Set the toe by adjusting the tie rod ends properly. Lock the outer tie rod ends by tightening the jam nuts.

IMPORTANT!: On electronic stability control equipped vehicles, if the steering wheel and front wheels are not centered properly it will trigger the anti-lock brake and traction control warning lights.

80. Recheck all hardware for proper installation and torque at this time. Reinstall the negative battery cable to the battery.

IMPORTANT! BE SURE TO BRING THE VEHICLE IMMEDIATELY TO A REPUTABLE ALIGNMENT SHOP TO BE ALIGNED!

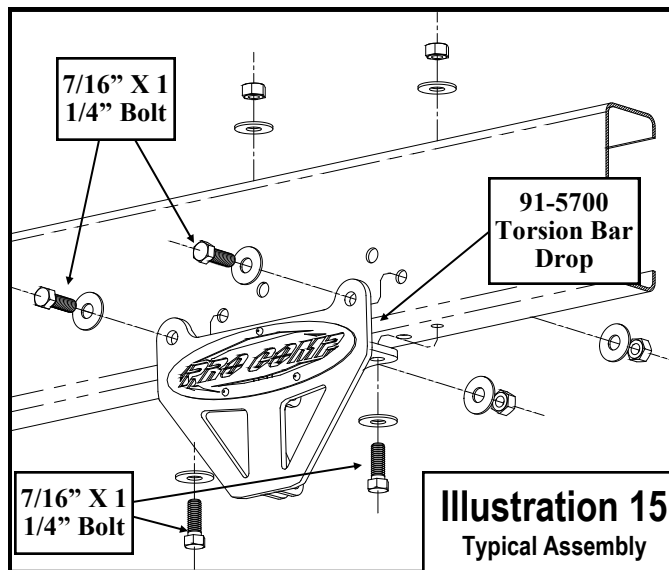

Illustration 15
 Typical Assembly

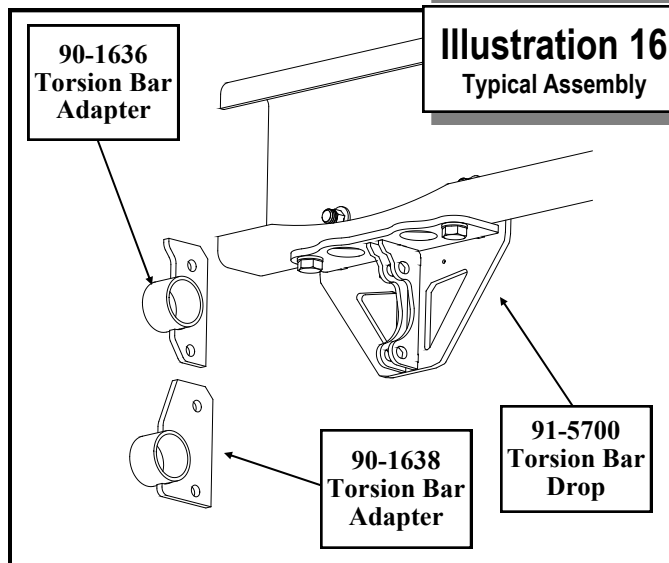

Illustration 16
 Typical Assembly

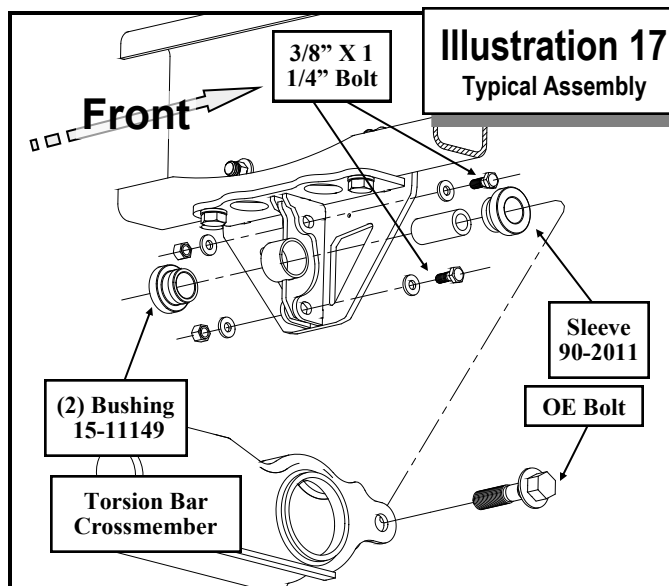

Illustration 17
 Typical Assembly

NOTES:

- ⇒ **On completion of the installation, have the suspension and headlights re-aligned.**
- ⇒ **After 100 miles recheck for proper torque on all newly installed hardware.**
- ⇒ **Recheck all hardware for tightness after off road use.**

Rear Installation

1. Raise the rear of the truck enough for the tires to clear the ground and use jack stands on the frame to support the truck. Remove the rear wheels from the vehicle.
2. Carefully remove the **OE** shock absorbers. It may be necessary to raise the differential housing slightly to facilitate their removal.
3. Remove factory brake line bracket. Attach New brake line drop bracket (**90-1817**) to the existing hole in the frame using the **5/16 X 1"** bolt and hardware provided. Attach the factory brake line bracket to the new bracket using the previously removed **OE** hardware. See ILLUSTRATION 18.
4. Remove parking brake cable bracket from rear frame rail. Attach the supplied parking brake drop bracket (**90-1083**) to the **OE** bracket hole location using the previously removed **OE** hardware. Attach the stock bracket to the new drop bracket (**90-1083**) using the supplied **5/16" X 1"** bolts and hardware provided.
5. One side at a time, support the differential housing on the side being modified. Remove the "U" bolts from that axle end and discard. Carefully lower the differential away from the **OE** springs. Remove and discard the **OE** lift block from its mount pad. Take careful note of the position of the factory spring packs.
6. Install the lift block (**95-401**), short end to the front, to the mount pad on the axle housing and raise the axle housing until the lift block hole fits around the new leaf spring center bolt. See ILLUSTRATION 19.

NOTE: Make sure the bottom of the lift block sits flat on the axle pad, if not the pin needs to be ground down until it does not hit

the axle.

7. Install the new "U" bolts over the leaf spring assembly and using the new washers and nuts supplied along with the existing spring plates, torque the U-bolt nuts to **120-130** ft./lbs. See ILLUSTRATION 19.
8. Repeat these steps on the other side of the vehicle.
9. Remove the **OE** bump stops from the frame. Install the rear bump stop spacers (**90-5705**) using the supplied **3/8" X 1 1/4"** bolts and hardware. See ILLUSTRATION 20.
10. Secure the **OE** bump stops to the bump stop spacers (**91-5705**) using the previously removed **OE** hardware. See ILLUSTRATION 20.
11. Torque the bump stop **OE** hardware to manufacturers specifications and **3/8"** hardware according to the chart on page **20**.
12. Install your new Pro Comp shock absorbers (**930001, MX6167 or FX6301**) using the previously removed **OE** hardware. Torque the **OE** hardware and torque bolts to **65** ft./lbs.

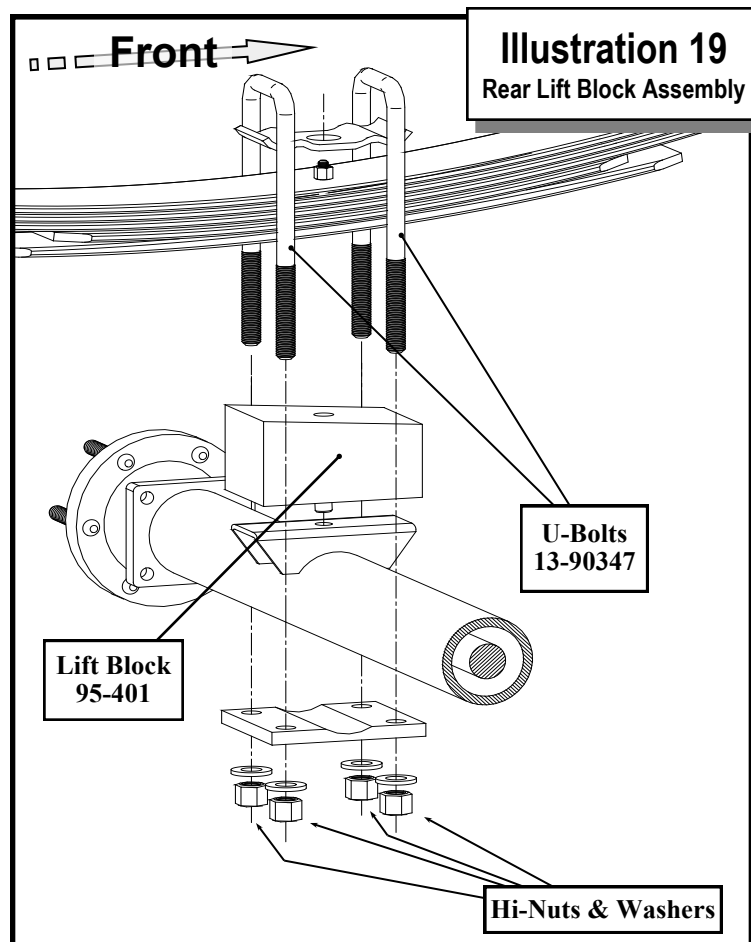
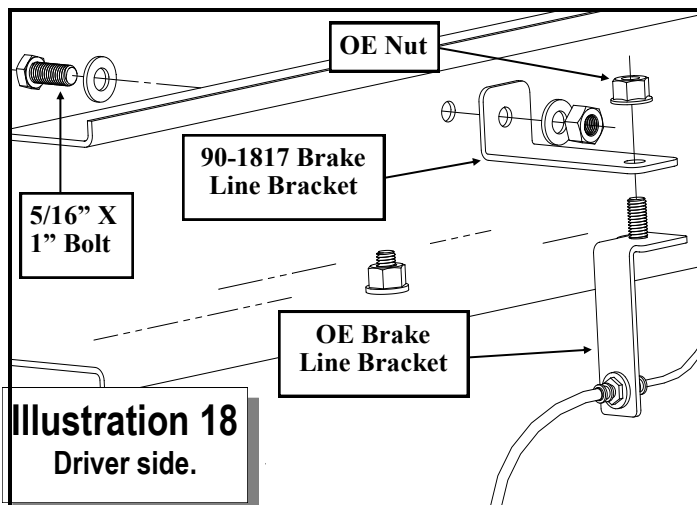

13. **For vehicles with a two-piece driveshaft.**
 Install shim kit (51255) by removing the two nuts that secure the center drive shaft bearing and lower the center support.
14. Remove the existing pressed in bolts from the “U” shaped shell of the support bearing and drill out these holes using a 7/16” drill bit.
15. In addition to the 1” aluminum block, approximately 1/4” of shim thickness for each inch of rear lift is needed. Install the 1 1/2” shim block (90-4056) and a combination of the other shims until the desired spacing is achieved. Use the new 7/16” hardware to secure the bearing to the frame and torque the fasteners to 55 ft. lbs. See ILLUSTRATION 21.
16. Test drive your vehicle to check for driveline vibration. Adjust the shim pack if needed.

NOTE: 1/4” of shim for each inch of lift is only a starting point. Only by driving the vehicle and adding or removing shims can the high speed vibration be totally eliminated. Any off the line vibration is caused by axle wrap up and cannot be eliminated with this product. Pro Comp traction bars will correct this condition. Contact your dealer for application information.

17. Install your wheels and tires and lower the vehicle to the ground.
18. After installation is complete, double check that all nuts and bolts are tight. Refer to the chart at the end of this document for torque specifications. (Do not retighten nuts and bolts where Loctite® may have been used).

NOTES:

- ⇒ On completion of the installation, have the suspension and headlights re-aligned.
- ⇒ After 100 miles recheck for proper torque on all newly installed hardware.
- ⇒ Recheck all hardware for tightness after off road use.

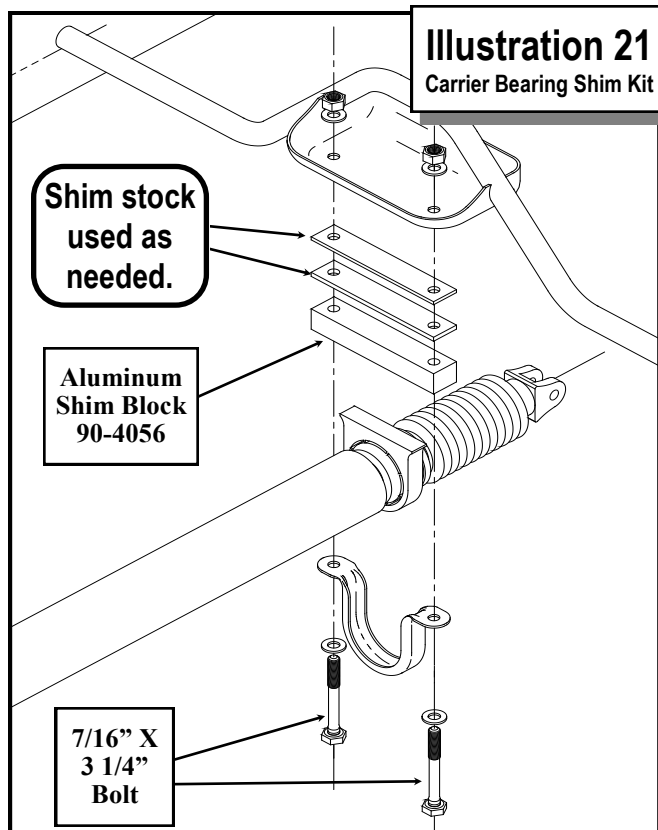
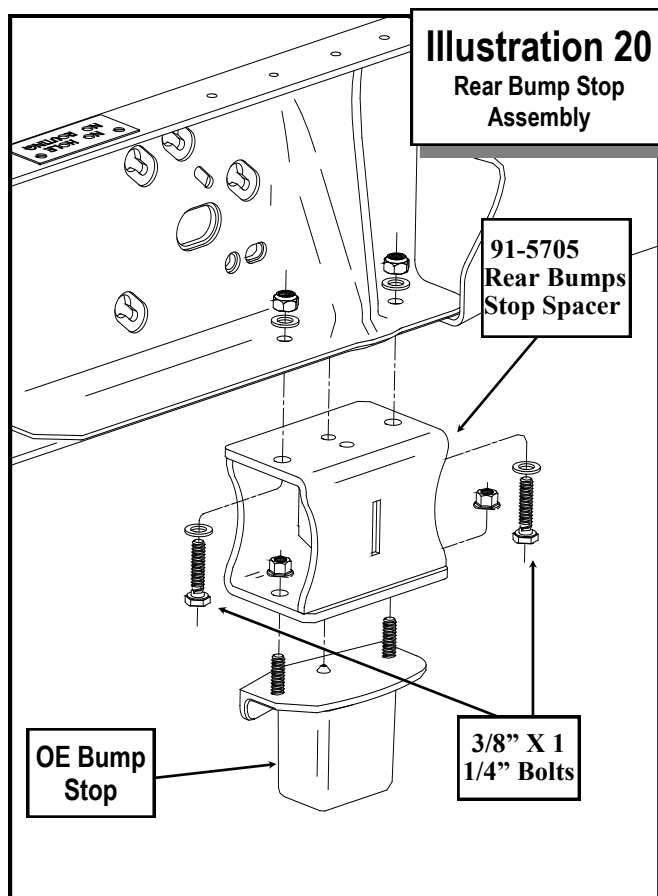

Bolt Torque and ID

Decimal System

Metric System

All Torques in Ft. Lbs.

Bolt Size	Grade 5	Grade 8	Bolt Size	Class 9.8	Class 10.9	Class 12.9
5/16	15	20	M6	5	9	12
3/8	30	45	M8	18	23	27
7/16	45	60	M10	32	45	50
1/2	65	90	M12	55	75	90
9/16	95	130	M14	85	120	145
5/8	135	175	M16	130	165	210
3/4	185	280	M18	170	240	290

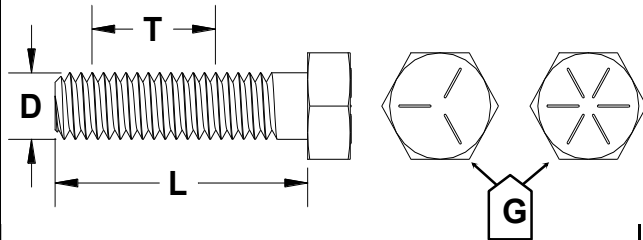

1/2-13x1.75 HHCS



Grade 5 Grade 8
(No. of Marks + 2)

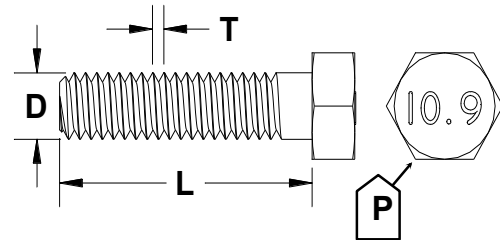

M12-1.25x50 HHCS



G = Grade (Bolt Strength)
D = Nominal Diameter (Inches)
T = Thread Count (Threads per Inch)
L = Length (Inches)
X = Description (Hex Head Cap Screw)

P = Property Class (Bolt Strength)
D = Nominal Diameter (Millimeters)
T = Thread Pitch (Thread Width, mm)
L = Length (Millimeters)
X = Description (Hex Head Cap Screw)

Revisions:

4.13.2020: Removed hardware pack 90-6728 from BOM box-2 and added 90-6782 to BOM box-2.
7.22.2021: Added K1084T and K1084M



The PRO COMP PROMISE WARRANTY

At Pro Comp, we know you have many choices when selecting products to personalize your vehicle. You should demand nothing but the highest quality available and have total confidence that the products you selected are the best in the industry. It is for these reasons that Pro Comp Suspension products are backed by the best warranty in the industry...the Pro Comp Promise!

Pro Comp promises that its products will last a lifetime or we will replace it free of charge. It's that simple! Because of our commitment to quality and manufacturing excellence, we are able to stand behind our products. FOREVER.

It is Pro Comp's Promise that if one of our suspension products breaks not due to misuse, neglect or vandalism, we will replace it. Whether you are the original purchaser or not, you can be assured that we will make it right. The Pro Comp Promise covers all suspension products including shocks and steering stabilizers. Buy Pro Comp Suspension today and enjoy it for the rest of your life!

That's our Pro Comp Promise!

Notice to Owner, Operator, Dealer and Installer:

Vehicles that have been enhanced for off-road performance often have unique handling characteristics due to the higher center of gravity and larger tires. This vehicle may handle, react and stop differently than many passenger cars or unmodified vehicles, both on and off-road. You must drive your vehicle safely! Extreme care should always be taken to prevent vehicle rollover or loss of control, which can result in serious injury or even death. Always avoid sudden sharp turns or abrupt maneuvers and allow more time and distance for braking! Pro Comp reminds you to fasten your seat belts at all times and reduce speed! We will gladly answer any questions concerning the design, function, maintenance and correct use of our products.

Please make sure that the Dealer / Installer explains and delivers all warning notices, warranty forms and instruction sheets included with Pro Comp product.

Warranty and Return Policy:

Pro Comp warrants its full line of products to be free from defects in workmanship and materials for the life of the product. Pro Comp's obligation under this warranty is limited to repair or replacement, at Pro Comp's option, of the defective product. Any and all costs of removal, installation, freight or incidental or consequential damages are expressly excluded from this warranty. Pro Comp is not responsible for damages and / or warranty of other vehicle parts related or non-related to the installation of Pro Comp product. A consumer who makes the decision to modify his vehicle with aftermarket components of any kind will assume all risk and responsibility for potential damages incurred as a result of their chosen modifications. Warranty coverage does not include consumer opinions regarding ride comfort, fitment and design. Warranty claims can be made directly with Pro Comp or at any factory authorized Pro Comp dealer.

IMPORTANT! To validate the warranty on this purchase please be sure to mail in the warranty card.

Claims not covered under warranty

* Parts subject to normal wear; this includes bushings, bump stops, ball joints, tie rod ends and heim joints.

* Finish after 90 days.

* Damage caused as a result of not following recommendations or requirements called out in the installation manuals.

Pro Comp MX Series coil-over shocks are considered a serviceable shock with a one-year warranty against leakage only. Rebuild service and replacement parts will be available and sold separately by Pro Comp. Contact Pro Comp for specific service charges. Pro Comp accepts no responsibility for any altered product, improper installation, lack of or improper maintenance or improper use of our products.

E-Mail: info@procompusa.com
Website: www.procompusa.com
Fax: (310) 747-3912
Ph: 1-800-776-0767

PLACE
WARRANTY REGISTRATION
NUMBER
HERE: _____